

TECHNICAL SHEET

CODE	5865
	HARD model filling MANHOLE COVER made of hot-dip galvanised 20/10 metal sheet, inclusive of T-shaped frame Th. 30/10 and holes for lifting.
TYPE	Recessed manhole cover
MATERIAL	S235JR - EN 10025:2005
FINISHING	Hot dip galvanized - UNI 1461
LOADING CLASS	Determined by the infill material
NORM	UNI EN124:2015

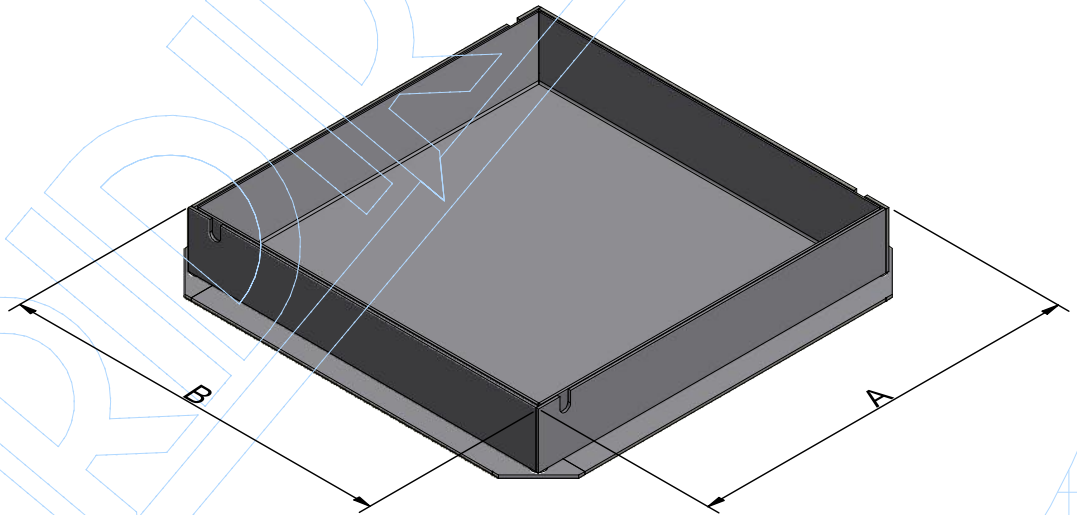

A	B	C	D	E	F
LENGHT mm	WIDTH mm	HEIGHT mm	TRAY THICKNESS	FRAME THICKNESS	WEIGHT Kg
650	650	65	2	3	15,96

The loading class cannot be established, as it will be determined by the assembly between the recessed cover and the filling material. The product will last longer as it will not be exposed to zinc corrosive conditions, so the use of glues and chemical cleaners containing these substances might permanently destroy the manhole.