

TECHNICAL SHEET

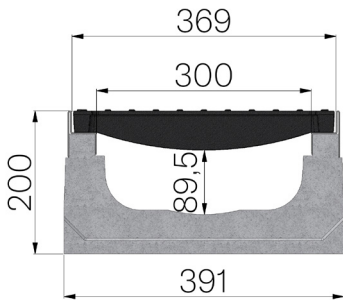

ASSEMBLED CODE	4R051SGG
DESCRIPTION	Vibro-compressed concrete channel MOD. R365 H2, with galvanized protective edge rails, c/w n. 2 x GJS500-7 ductile iron gratings dim. 365x500 H30 mm. installed and locked, painted. Channel runoff section cm ² 291. Load class D400 according to EN 1433:2008 Norm, if installed following manufacturer instructions.
PRODUCT LINE	Drainage channel type "M"
STANDARD	EN 1433:2008
LOADING CLASS	D400 - EN 1433:2008
INTENDED USE OR USES OF THE PRODUCT	Collection and channelling of surface water into areas subject to pedestrian and/or vehicle traffic according to the indicated flow rate.
DURABILITY	Grades of weathering resistance: W +R (§6.3.3.3 EN 1433:2008)
QUANTITY PER PACK	15
1) CHANNEL	4R051S
MATERIAL	Vibro-compressed Concrete
SERIES TYPE	R series 365
SECTION TYPE	H2
PROFILE TYPE	Galvanized edge
VERSION TYPE	Normal without built-in slope
WATER FLOW LT / SEC	0,5%=120 - 1%=169 - 1,5%=207 - 2%=239 - 3%=293
2) GRID	4R05GS1
GRID TYPE	Ductile-iron Grid
MATERIAL	Ductile-Iron GJS500-7 : EN1563
SURFACE FINISH	Paint coating



Article dimensions mm	Inner width mm	Runoff section cmq	Weight Kg/each
1000 x 391 x H 200	300	291	125