

# Assembly steps for the VRUZEND 18650 battery pack assembly kit.



<https://www.facebook.com/groups/Vruzend/>

# Cap structure and design

Each cap has a dove tail pattern made up of two adjacent tails and sockets

This makes it easy for you to slide the caps in and out.

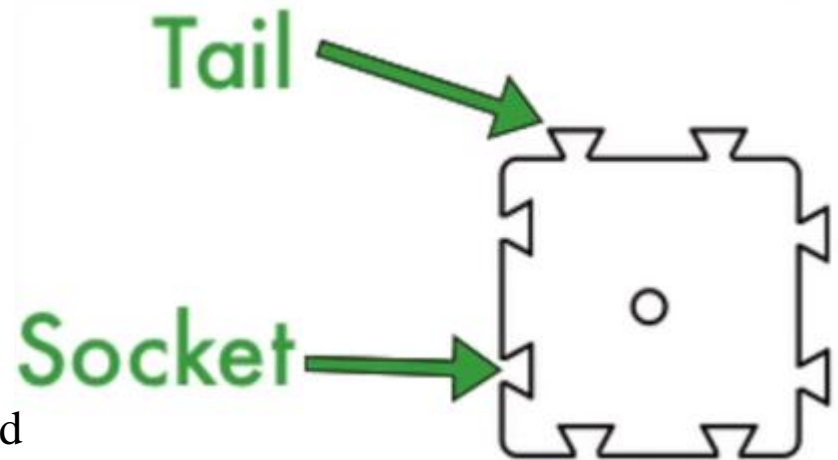

Make sure to orient all the caps in the same direction at the time of assembly.

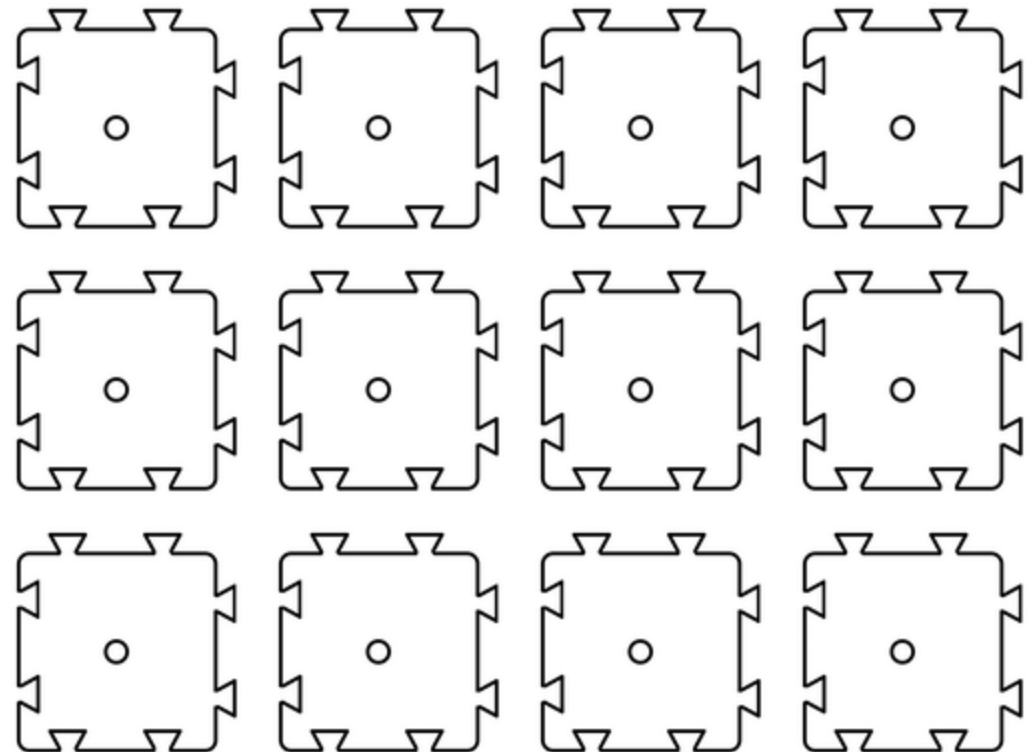

# Starting off



Start out by first deciding upon the size of pack you need.

Start assembling the caps. Make sure to make the columns first.

So a 13s4p pack will have 13 columns of 4 red caps and 13 columns of 4 blue caps.

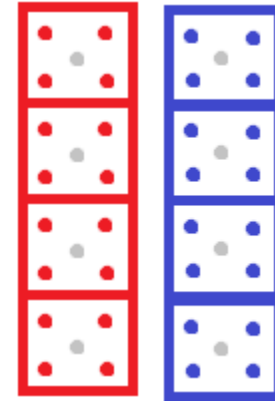

Similarly a 10s5p pack will have 10 columns of 5 red caps and 10 columns of 5 blue caps.

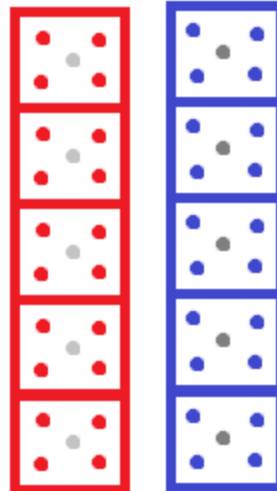



**Make the columns!**

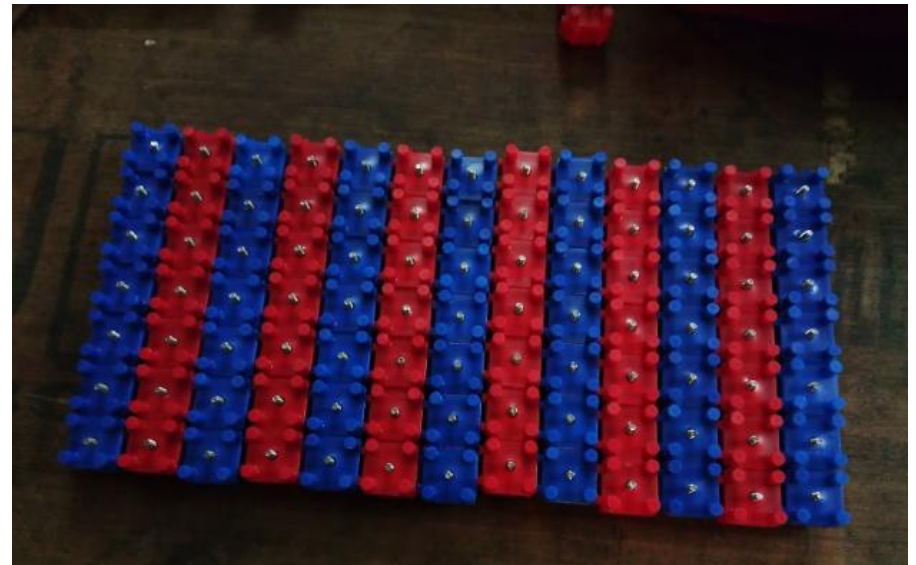

# There are two ways you can make a pack using these caps.

## Method 1-Column Method

First method is placing the cells in the individual columns made.



**Pay attention to the orientation of your tails/socket. Example, if at the bottom your tails are facing the left then at the top they should face the right.**

View this step at <https://youtu.be/9Pxq4Au5iuc?t=4m57s>



Push the caps down gently using a block of wood or a clamp.

<https://www.youtube.com/watch?v=9Pqx4Au5iuct=5m20s>



**From one leg end to the other the distance should be 91mm-92mm for the V1.5 standard kit and 93mm for the V2 high powered copper kit**



Using the voltmeter check that every cell has made a connection.



Once you have all your groups assembled line them up such that the tails and the sockets can slide into each other.



**\*This is why we had asked you to keep the tails/socket facing the opposite sides at the top and bottom ;)**



Once you are done assembling the columns, Start sliding them in to form a block.

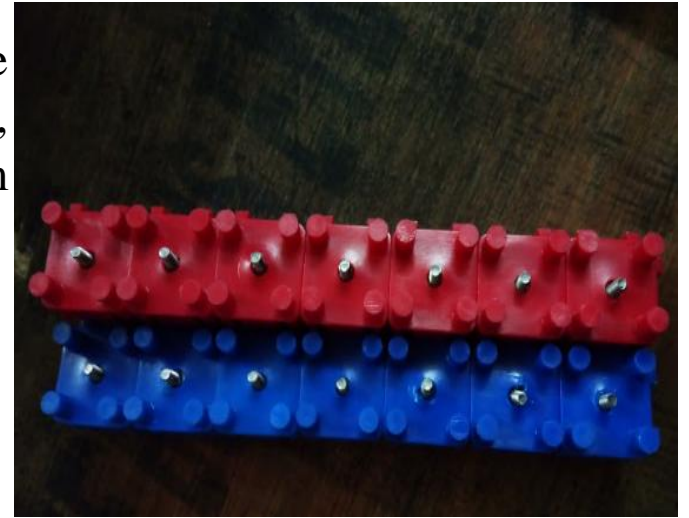

You may want to use a light hammer (100g) to gently tap on the cap legs to slide them in and level the block.



# Method 2- Block Method

**\*For those having used the system before and now have a hang of it.**

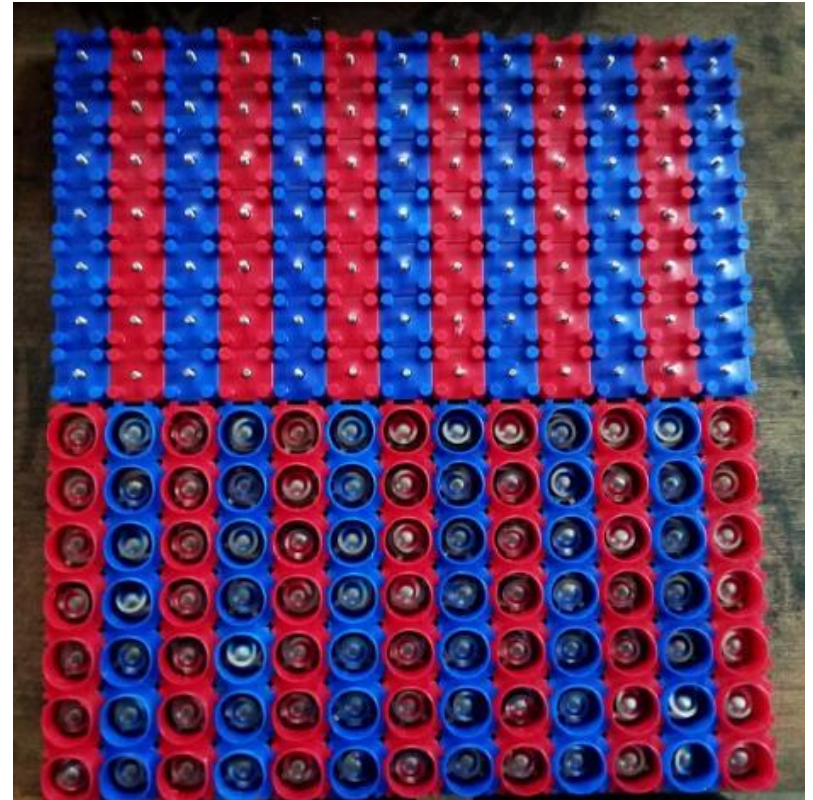
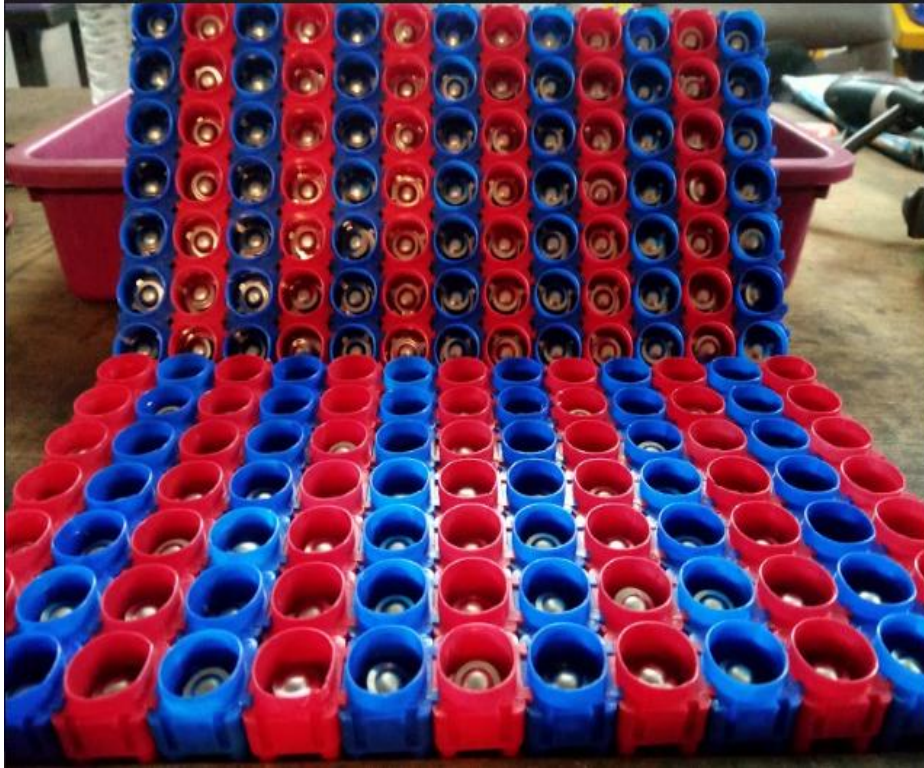

Notice how the two blocks for the top and bottom side mirror each other. That is for a red row on one side there will be a blue row on the other side, to mimic the positive negative cell polarity.



Place the cells into the block.

Make sure that it is the positive terminal going **INSIDE** the red cap and the negative terminal going **INSIDE** the blue cap.

It is a very common mistake to insert the negative terminal into the red cap and keeping the positive terminal upwards facing you. So be careful!



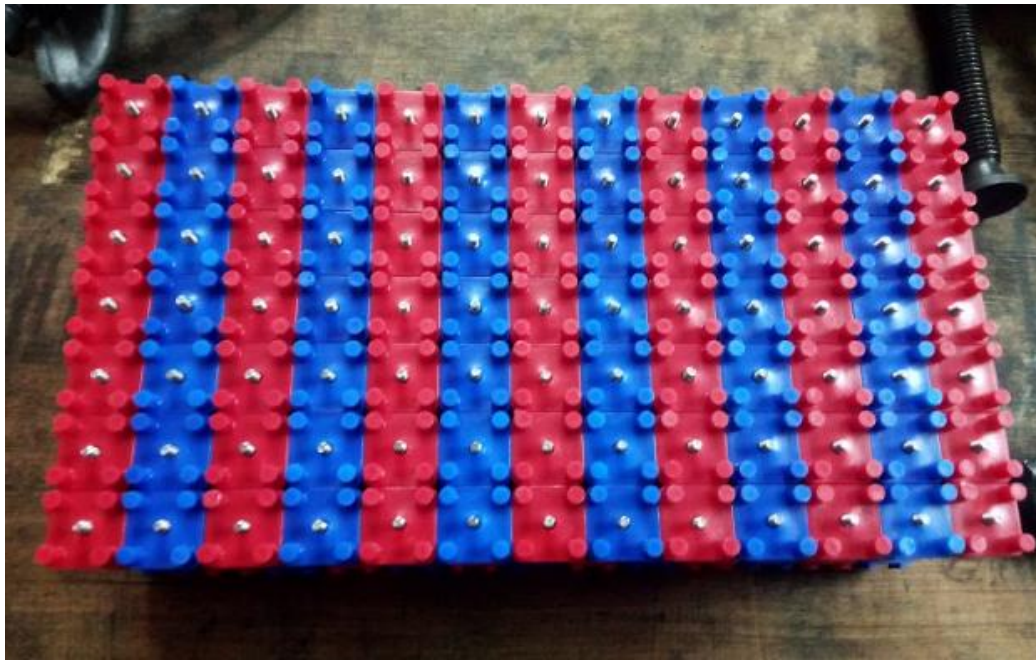

Place the block on top of the cells  
(Match the polarity of the cells to the  
colour coded block ).

Once done use clamps to secure the  
caps onto the cells.





Start of by clamping at the centre. Then move the clamps to the corner of the pack and repeat.

**Maintain clamping distance as 92mm from one leg end to the other.**

Add the thickness of your wooden plank to this clamping distance and then maintain this distance throughout.

You can make a mark on your clamps so as to not to tighten it further.

This mark will prevent you from over clamping at the centre as measuring the cap distance for a cell at the centre of the pack will be difficult.



Like done in method one, using a Voltmeter check that every cell has made a connection with the internal contact of the cap.

If the clamping step was done right, every cell will make a connection.

In the rare case where a single cell might not have made a connection, press down on the cap gently with a blunt tool like the butt of a screw driver.

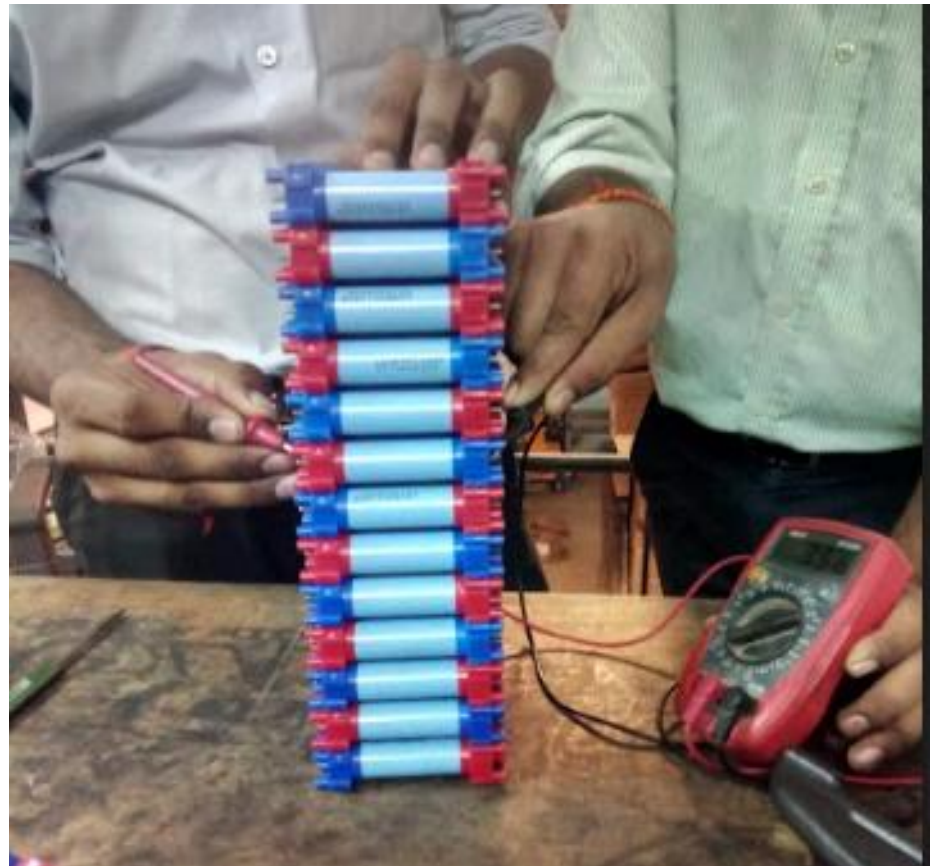

**Your blocks are ready!!**



# Mount the bus bars and do the connections



## High Amp draw applications



It is advice able to make parallel modules and have them connected in series.

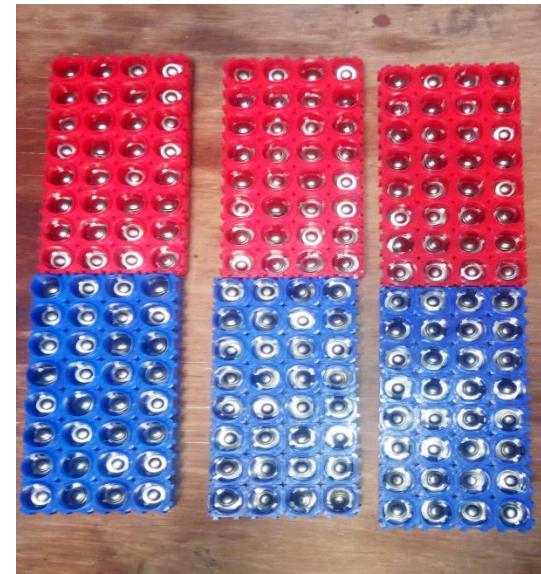

Use copper wires along with the bus bars to facilitate the flow of extra current.



Sandwich the copper wire between the bus bars and use the nuts to firmly fix it in place.



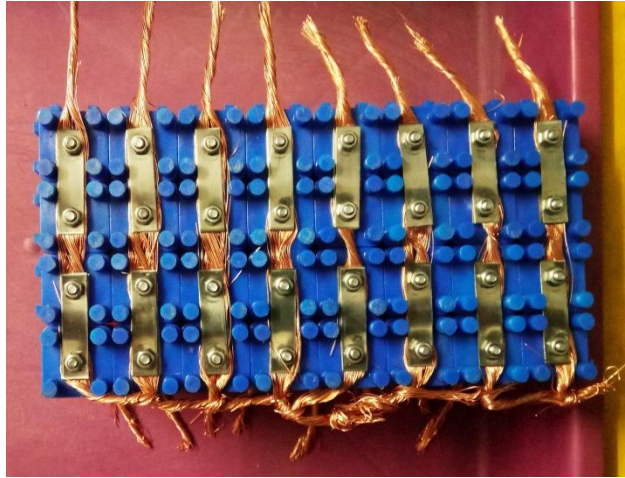

The gauge of your wire would depend upon your amp draw. The pic shows the copper wires connecting groups of 4 cells i.e 8 columns and 4 rows. The module is 8x4 module. Instead of using 8 copper wires, you could use just 4 copper wires by making groups of 8 i.e 4 columns and 8 rows. However that would mean a lot more current would be flowing through the wires which may require your gauge to be thicker.

# High amp draw 14s6p pack using copper wires as shown on page 17

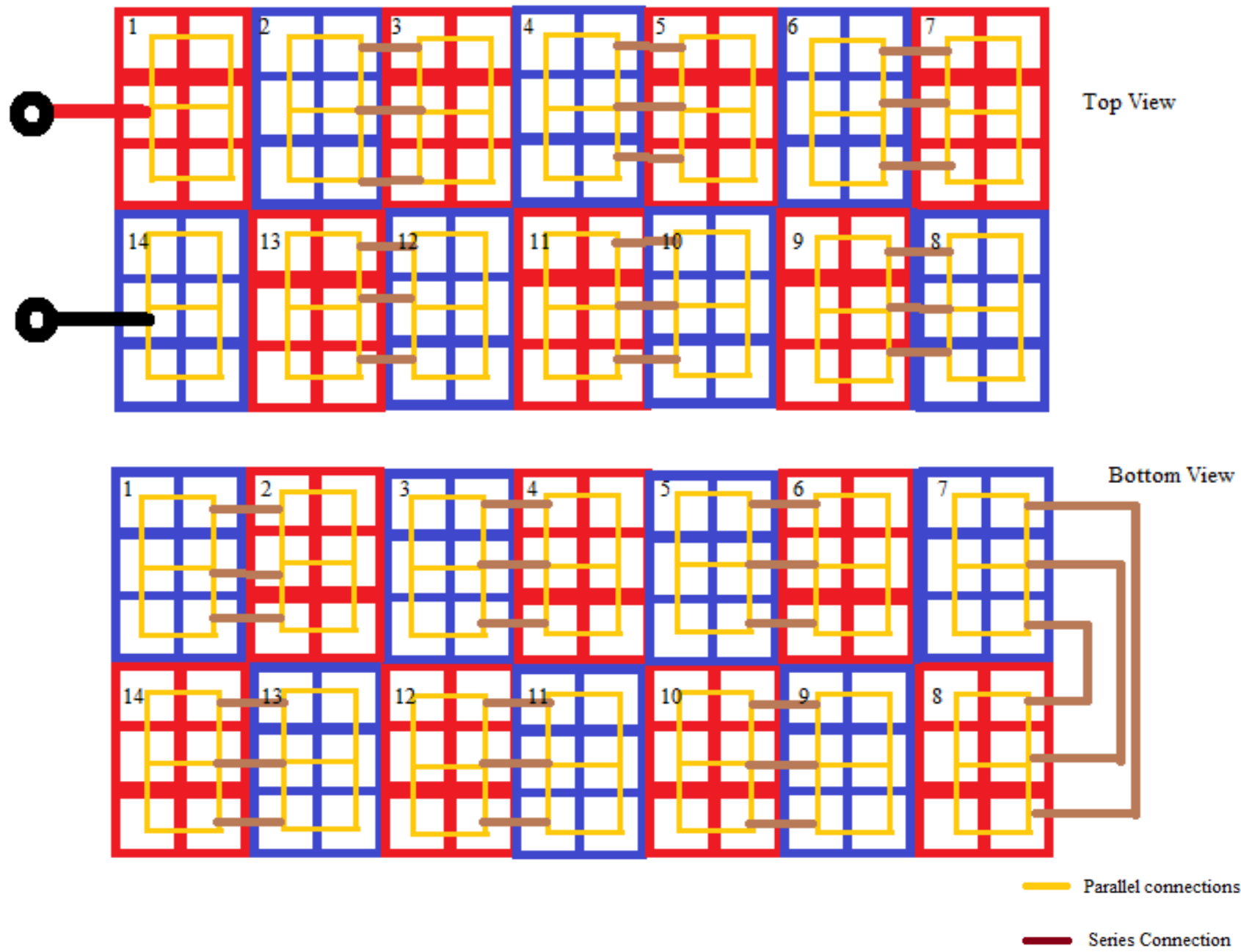

## Pack insulation and Casings

**Micah St Clair uses electrical insulating tape to insulate his pack for his kids quad bike !**



**Stanley Dimant uses a plastic box as an outer housing for his 16s4p pack which he uses for astro photography !**



# Now that you are done building it, what if you need to dismantle the pack?

Undo the bus bars from the part of the pack from where you want to replace/remove the cells  
(Pic is for illustration).

Say you do away with bus bars for 5 columns from the right.

Slide in a steel foot scale (ruler) or a thick strip into the columns and leverage it upwards.

Work your way inwards from the corner leveraging one column at a time.

Do this a couple of times before the caps begin to lift.

Notice how the caps at the bottom are still in place but the ones at the top have begin to pop.

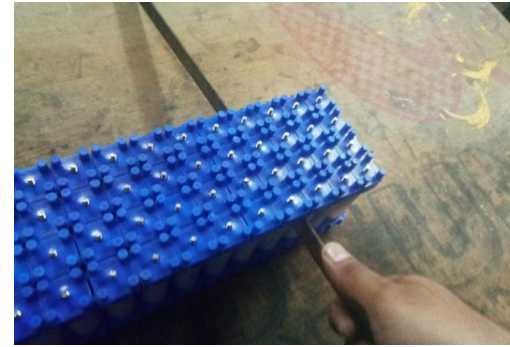

# How to connect a BMS to the kit?

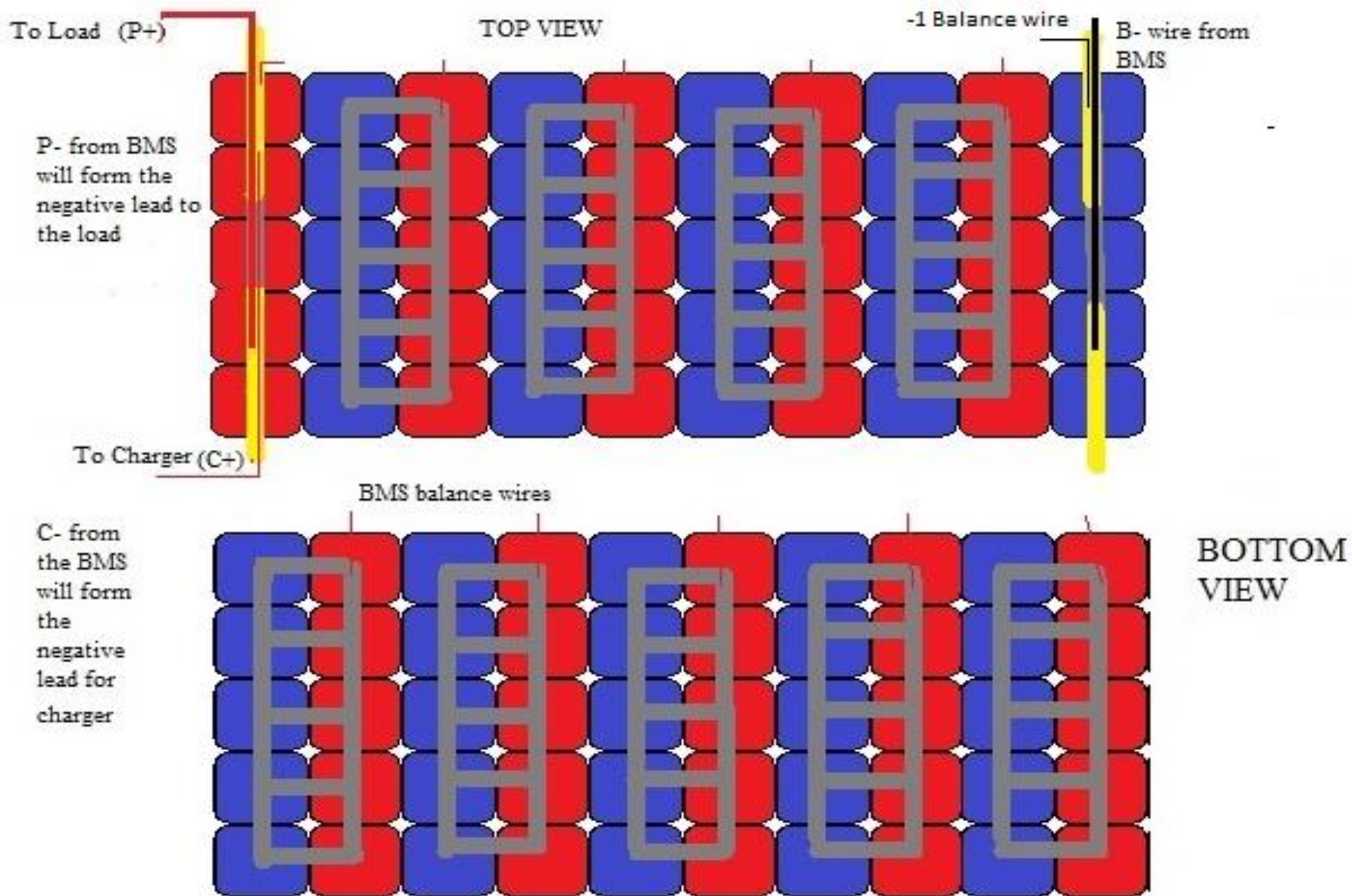

View the detailed video at <https://www.youtube.com/watch?v=m4DGDkwFr54&>

## How to incorporate cell level fuses?

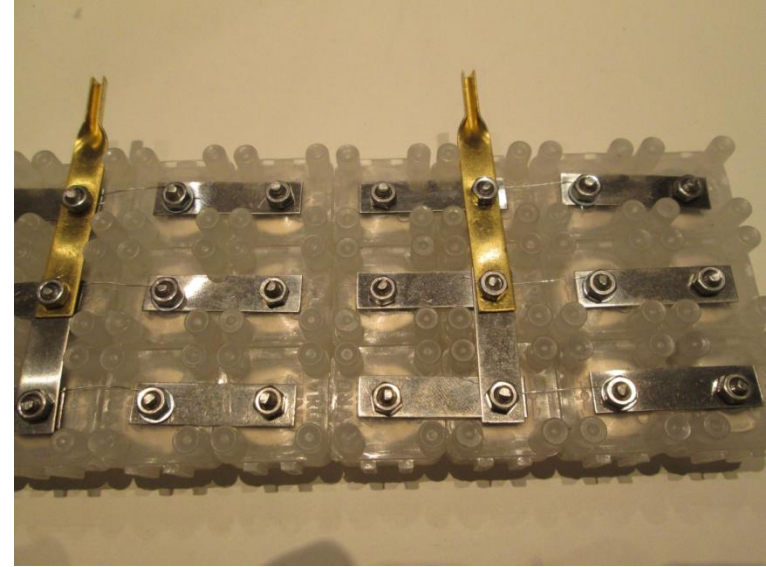

**Wound the fuse wire around the threaded post and secure it with the nuts.**

**Simple and straight forward.**

# To use cell level fuses to build a power wall

- Build modules in parallel and then series connect the modules. That is if you need your powerwall pack to be 14s24p then make 14 modules of 24 cells. Cells within a module are connected in parallel. Series connect these 14 modules to obtain your pack of 14s24p
- Place the bus bars on top of adjacent cap legs. Use axial glass fuse to connect each cell to the bus bar.
- Wound the fuse around the threaded post and secure with the nut.
- Solder the axial glass fuse onto the copper bus bar.

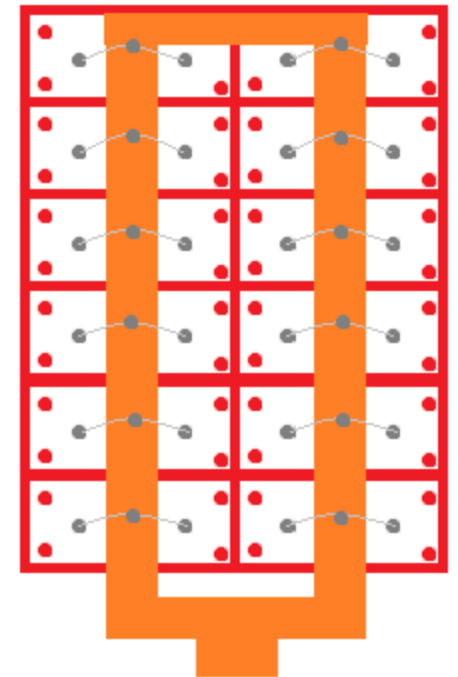
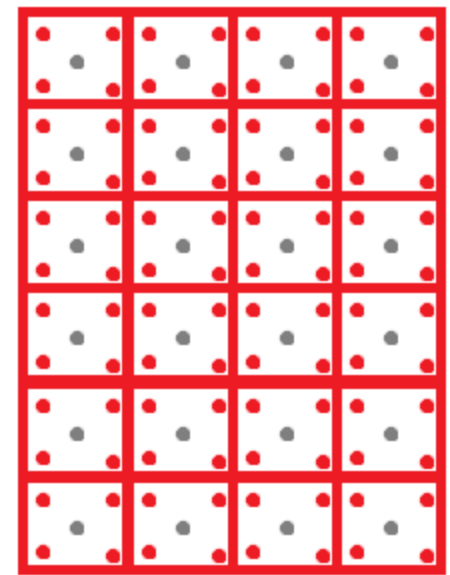
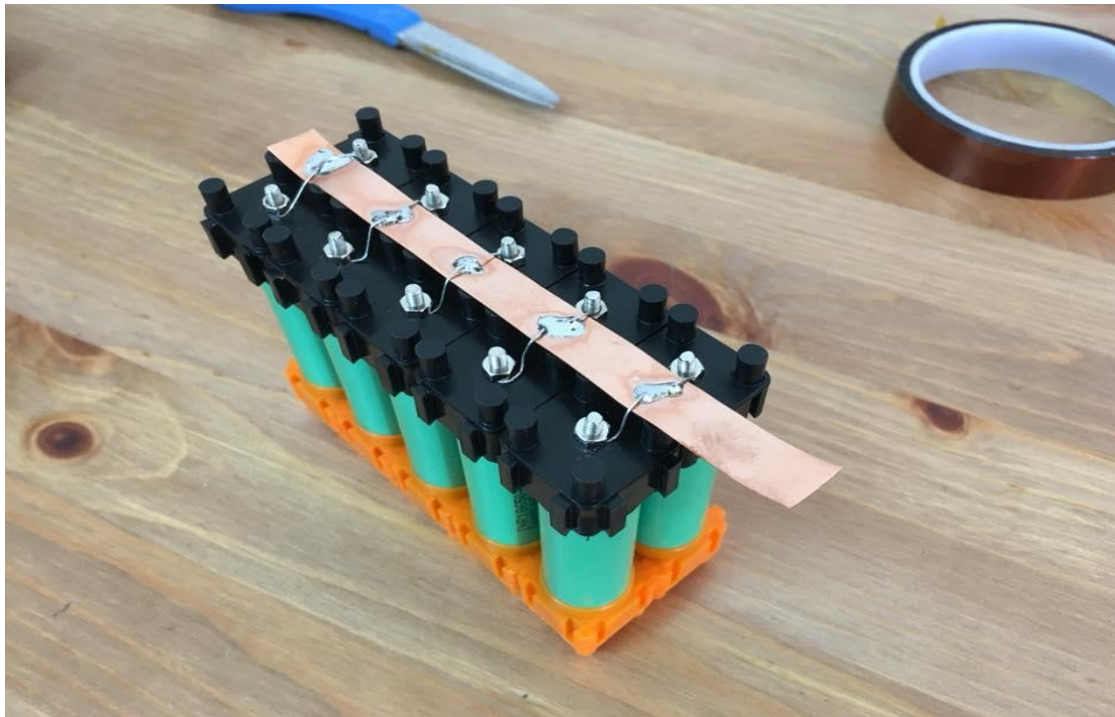

# To use cell level fuses to build a power wall (Contd..)

Say, that instead of 24p if your pack were to be 25p or a scenario where in you would need to add one more bus bar just for a single column; what you could do is

- Either use an extra bus bar and attach the cell level fuses of that particular column onto that bus bar or;
- Increase the number of rows like shown in figure two, even if the number of cells are odd, one or two columns can have those extra cells. Like in figure 2, column 4 has 7 cells instead 6 to accommodate that extra 25<sup>th</sup> cell.
- It is advice able to use cell level fuses on both the terminals, that is the positive terminal as well as the negative terminal. It adds extra redundancy to the pack and is a good practice.**
- For the copper bus bars you could either use copper strips or make braided bus bars as shown by flyjabiru11  
<https://www.youtube.com/watch?v=TedqvvdDatMk>

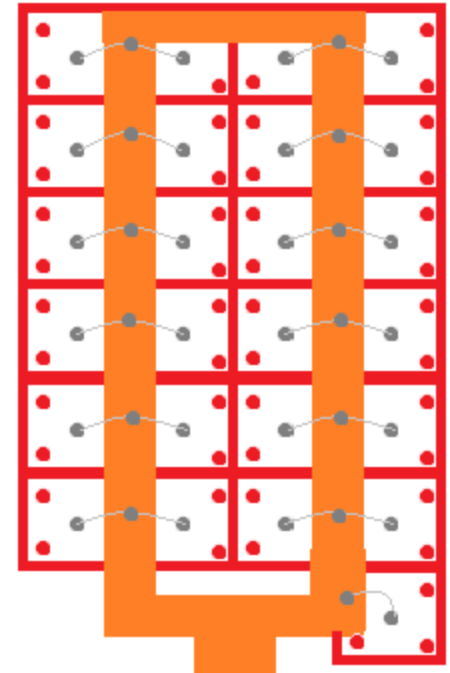
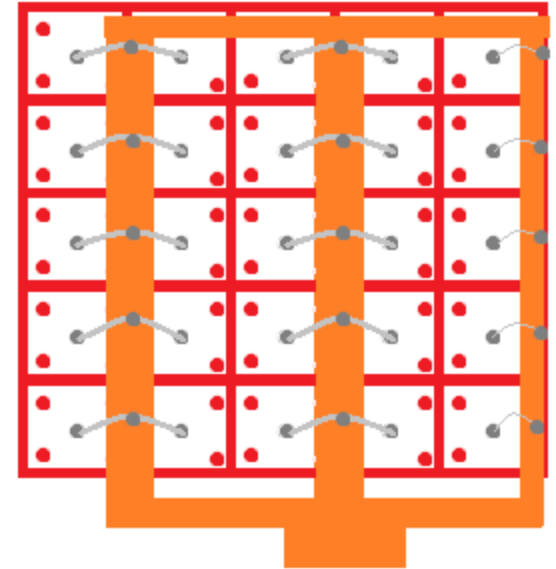

## Custom/Alternative parallel connections.

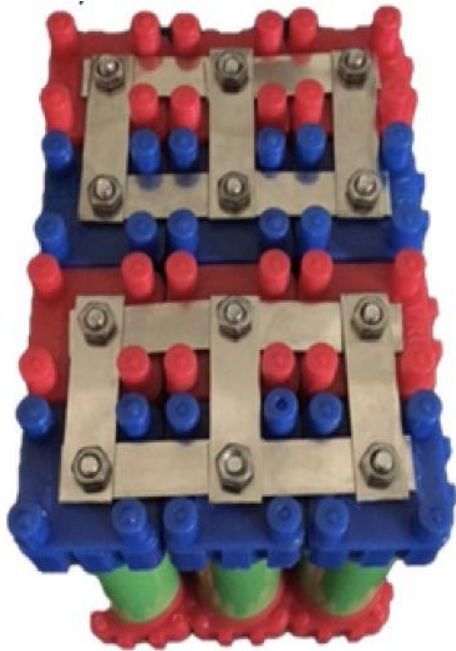

Normal bus bar parallel connections

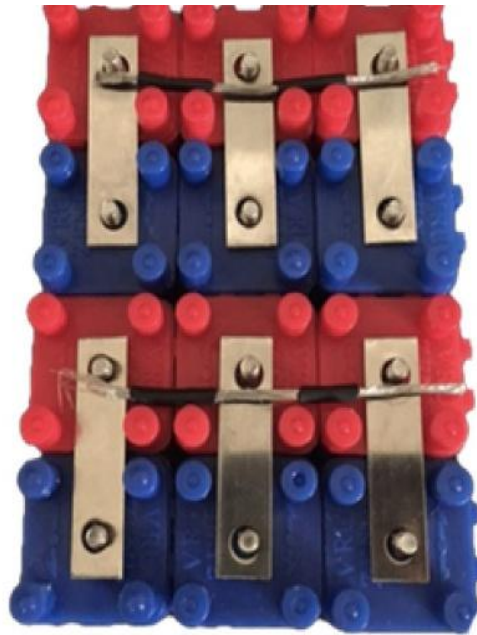

Preparing wires for parallel connections

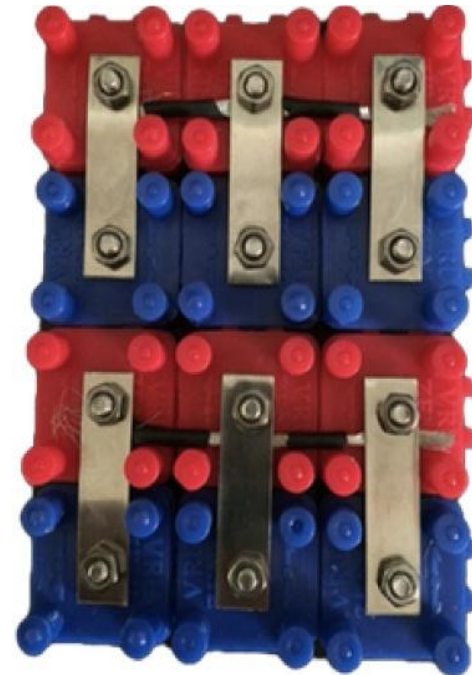

Parallel connections made with wires instead of bus bars

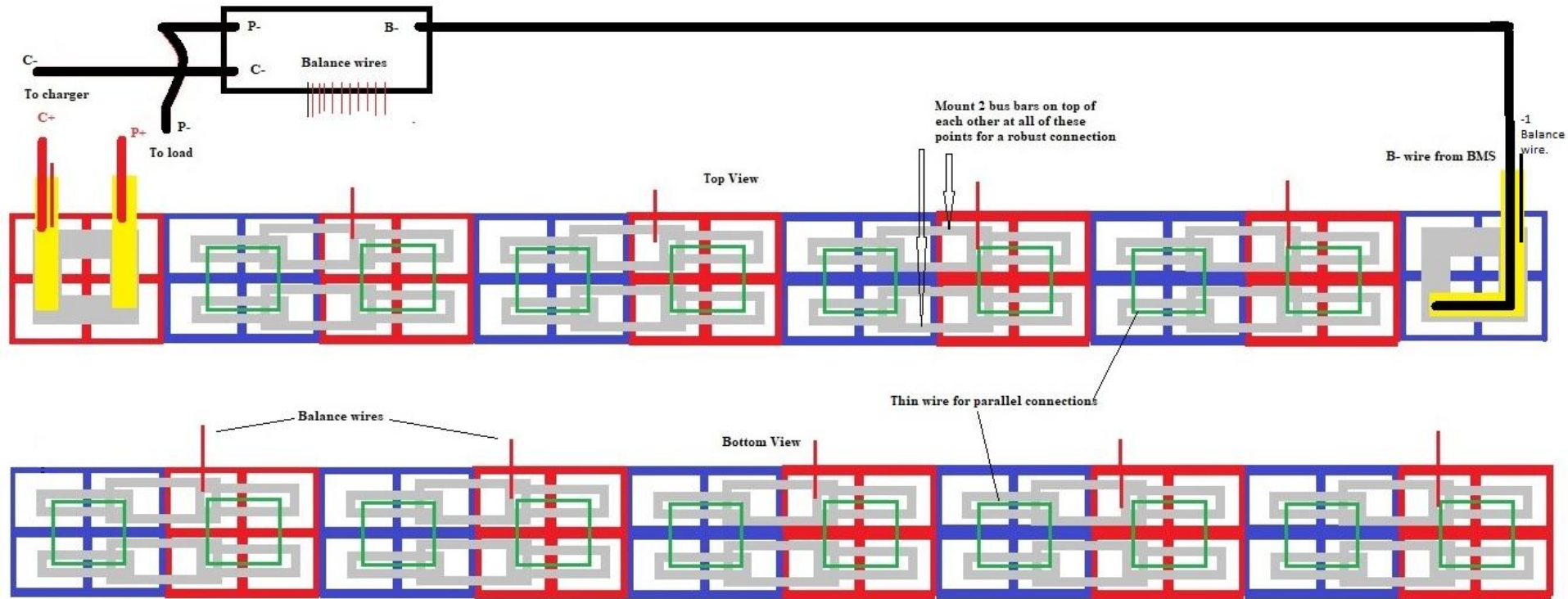

**A 10s4p battery in 20\*2 config built for a skate board.**

**The parallel wires can be set up in a way as shown in the previous pic.**

## Cell sleeves or insulating tape if your cells are a bit thinner than 18mm

The caps are designed to take in a wide variety of the 18650 model cell. Some of these models are a bit narrower than 18mm like the Panasonic cells and some of them Like the LG Mj1 are about 18.5mm.

The ID of the cap is about 17.90mm to match the Panasonic cells. However you might still find them to slide into the caps a bit loose.

What you could do is either use cell sleeves around the terminals or wind a round of insulating tape around the cell terminals. When you wind the tape, make sure to bend the tape at the terminal edge. This way it wont crumple up when you push the cell into the cap.

Also by bending the tape at the cell edges, you will be providing an added insulation for the positive terminal!

\*The cells in the pic have been taped to 19.5mm to torture test the cap.



**Cell sleeves or insulating tape if your cells are a bit thinner than 18mm**

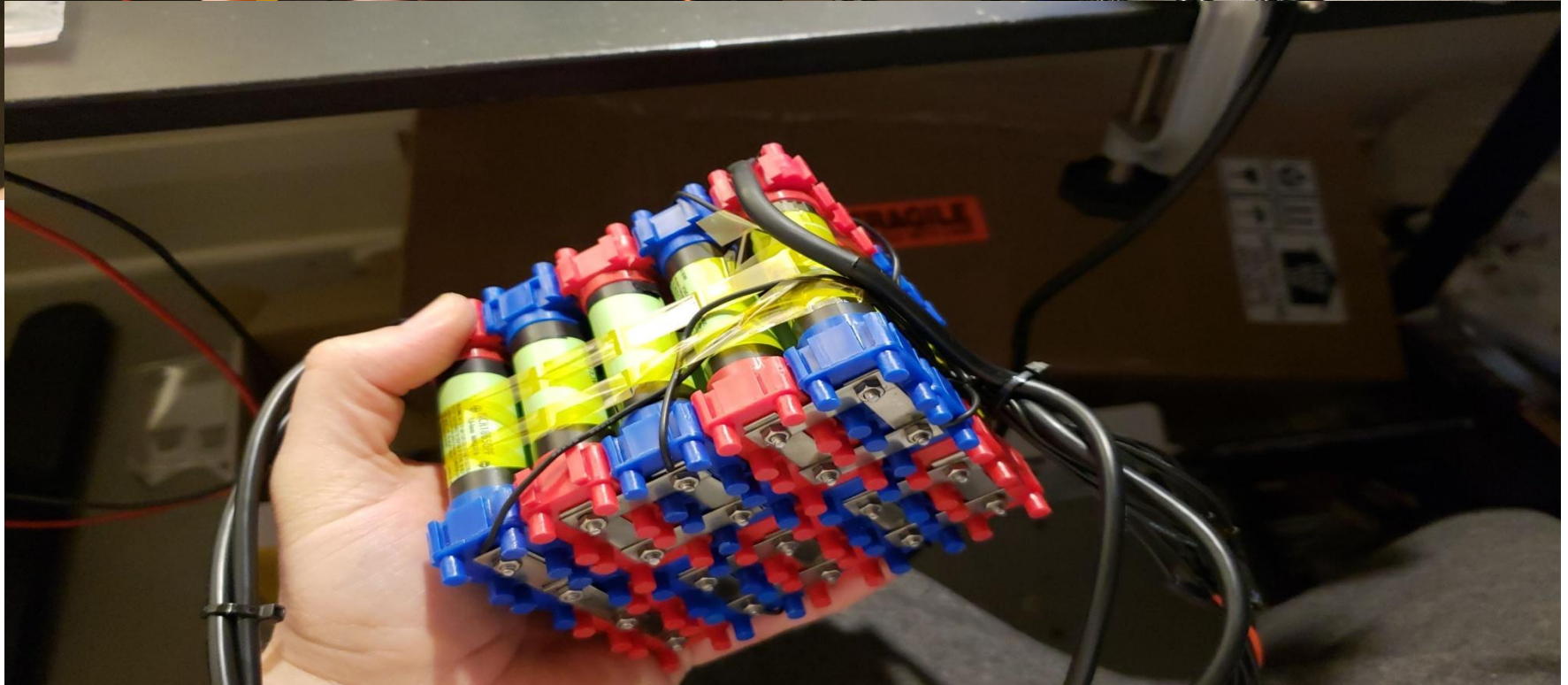
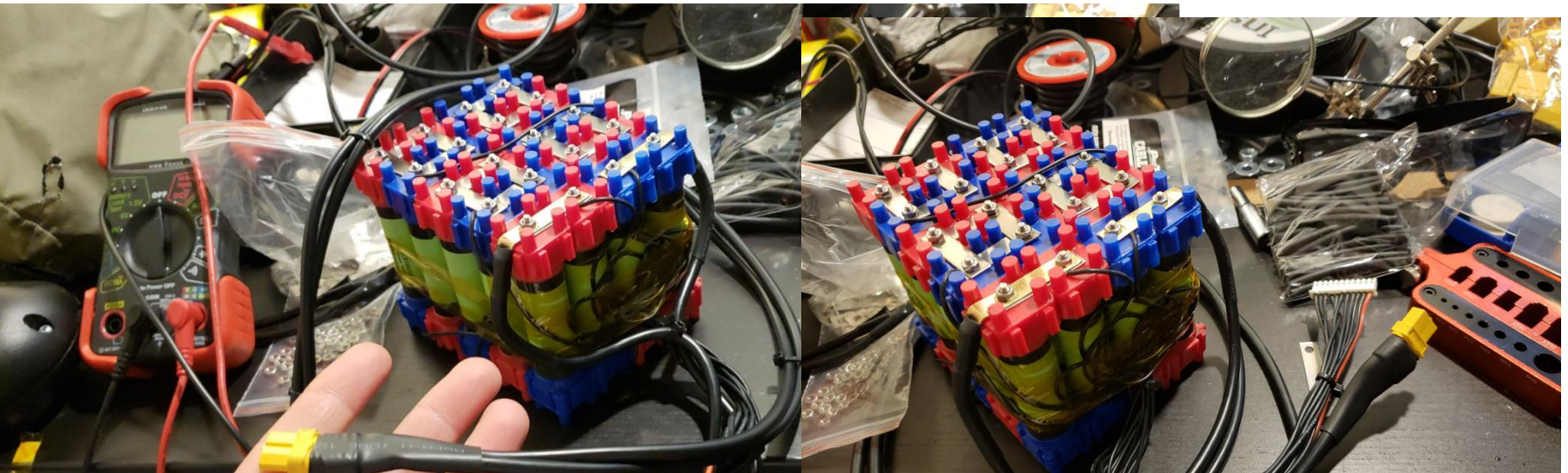

## Sandwich plates for maintaining pack connections during mobile applications



Kindly go through the link. You could use wood, metal plates or even polycarbonate as your sandwich plates

<https://vruzend.com/adding-sandwich-plates-to-ensure-continuous-connections/>

Power it up!!

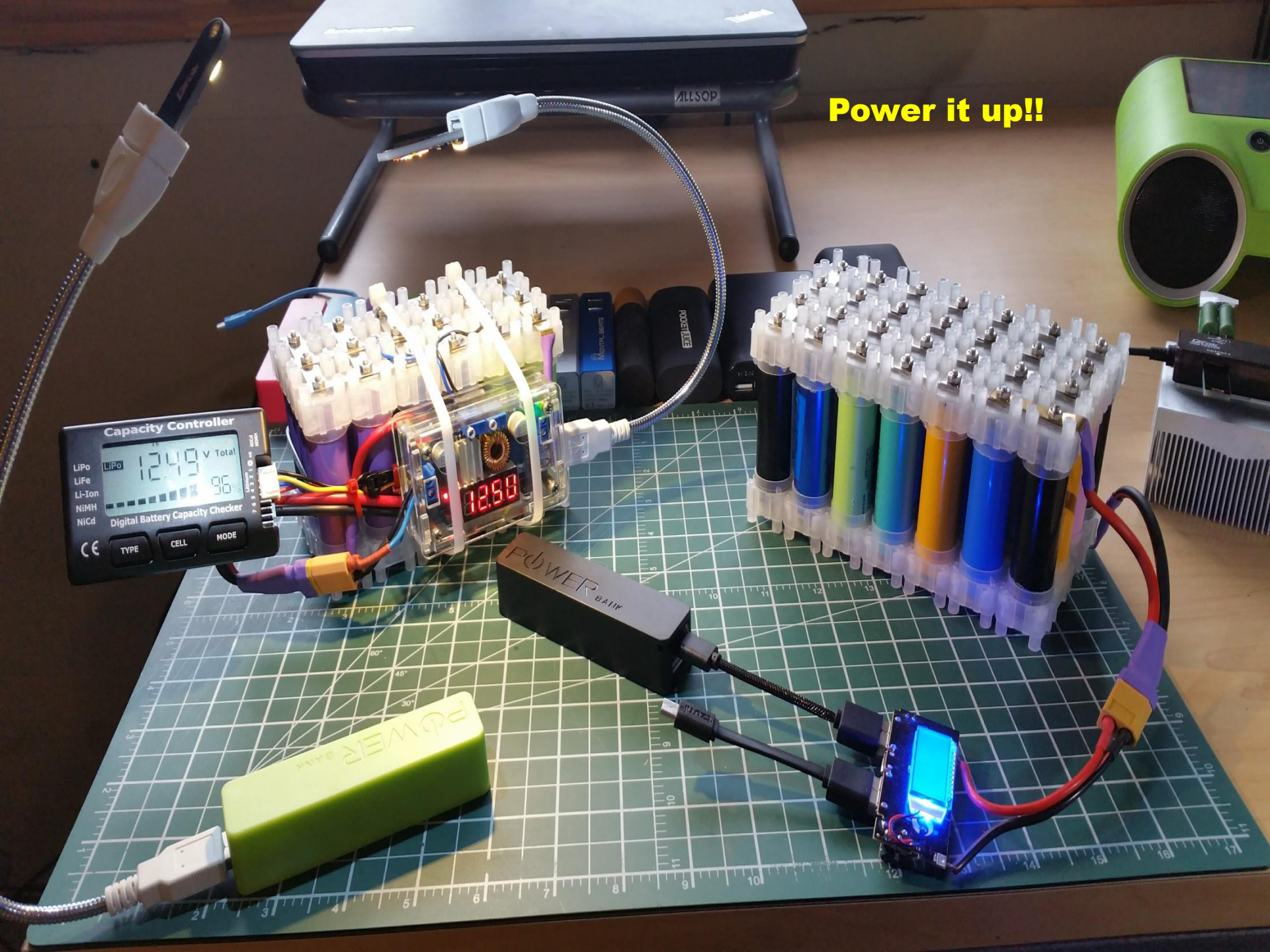

Capacity Controller  
LIPO 12.49 V Total  
LiFe 96  
Li-Ion  
NIMH  
NiCd  
Digital Battery Capacity Checker  
TYPE CELL MODE

POWER BANK

POWER BANK



**Visit us !!**

**[www.vruzend.com](http://www.vruzend.com)**

**<https://www.facebook.com/groups/Vruzend/>**